

**You have been sent this newsletter because you have subscribed, or purchased product, or made an enquiry to [www.decibelhifi.com.au](http://www.decibelhifi.com.au) . If you do not wish to be on our newsletter mailing list, please click on the SafeUnsubscribe button at the bottom.**

## In This Issue

Record cleaning news  
Small amplifier news  
Origin Live news  
Thoroughbred power products  
Musical Fidelity V-DAC  
New lower cost Pro-Ject turntables  
Other Products

## Quick Links

[In the Groove roller cleaner](#)  
[Record Cleaning Service](#)  
[Bulk Nagaoka style sleeves](#)  
[DAYTON DTA-100](#)  
[Record ReVirginizer](#)  
[AMPHONY transmitter/receivers](#)  
[SURE amplifier boards](#)  
[Onyx & Zephyr tonearms](#)  
[THOROUGHbred power](#)  
[MUSICAL FIDELITY V-DAC](#)  
[PRO-JECT turntables](#)  
[LADS CD treatment](#)  
[Red Rose Music Vol.1](#)  
[CD/SACD/BD Titles](#)  
[Audiophile LPs](#)

## Dear Brian,

The sunshine state has been a bit damp over the last few weeks. Where we are located in Brisbane was well away from the flooding but we have been involved nonetheless helping others to clean up. Our daughter opened a new business in Milton two days before the flooding. We helped her move in the Pilates equipment and furniture on Sunday, she opened on Monday, we moved the equipment out on Tuesday and on Wednesday there was 700mm of water in the studio. But the walls have been re-sheeted, floor re-laid, electricity re-connected, re-painting done and she opened again just two weeks later. To those still struggling to get going again we wish you the very best.



Record cleaning is an unfortunate necessity for vinyl LP owners and there are now many products on the market to assist. But they all take time to apply, and for most of us time is in short supply. So we now offer a record cleaning service which we hope will solve the problem for some customers. See below.

Do you remember the great hi fi shows during the 70s? Exhibitors displayed and demonstrated their equipment in hotel suites and were invaded by enthusiasts over several days. We haven't seen them in Australia for many years but there are still many overseas. Well, it's going to happen again. The Australian Audio & AV Show will be on at the Marriott Hotel in Melbourne from October 21st to 23rd. We intend to be there with our most important products like Origin Live, Ohm Acoustics, and Graham Slee Projects. We will keep you updated with progress in future newsletters and hope we can meet many of you there.

Musical regards

Brian Maddern  
07 3344 5756  
[enquiry@decibelhifi.com.au](mailto:enquiry@decibelhifi.com.au)

## Record cleaning news

The major new record cleaning product to hit the market last year has been the Record ReVirginizer. We have had positive feedback from many customers as to its effectiveness and several have purchased second or more bottles. One customer says he is cleaning 20 LPs from each bottle. There's a new review on ToneAudio <http://www.tonepublications.com/gear/cure-tough-to-clean-records/>

Another useful tool for cleaning is the Nagaoka roller cleaner. It can't remove mould or imbedded grime but is good for a quick removal of dust prior to playing. Only problem has been the cost (\$82.50). We now have an alternative. The "In the Groove" is larger, stickier, and less than half the price. The roller is coated with a soft, sticky material that sinks into the grooves and pulls out debris. Once it gets dirty you simply wash it under water and dry it off and it's back to new. It is also very effective on flat screen TVs, iPads, monitors, in fact any flat surface. And the price? Just \$29.70. We expect, given its many applications and price, it to be very popular. It's in the [Vinyl Record Cleaning category](#).

**Record Cleaning Service.** We have decided to offer a record cleaning service for those who don't have the time to do it themselves. The price is \$55.00 for 25 LPs. You will need to post them to us (without the jackets) in a suitable carton (eg. the ones we use to send you sleeves). 12 or 13 LPs can be packed into each LP mailer and two mailers can be taped together to reduce postage. The weight is just under 4Kg which costs \$19.15 in a 5Kg Express Post satchel from anywhere in Australia. Registered post is a little cheaper from the eastern states. We will clean them on our Moth record cleaning machine with Disc Doctor QuickWash fluid, put them in new inner sleeves (your choice) and post them back to you. The total cost when you take into the account postage to and from and the cost of the sleeves is about \$4.30 per LP. Of course customers in or near Brisbane can drop off and collect. We have already had one instance where a customers insurance company is willing to pay for the cost of cleaning of 300 LPs which were water damaged in the floods.



To place an order go to the [Record Sleeves category](#), add the Record Cleaning Service (code RCS) to the cart, then select the inner sleeves you want used, and complete the order. We will receive your order and know that your LPs are on their way to us. Depending on demand we would expect to have your records cleaned and on their way back to you within a week.

**Bulk Nagaoka style inner sleeves.** The Nagaoka 102 sleeves are very popular and we now have identical sleeves in bulk. These sleeves come from the same factory that produces them for Nagaoka but they are not branded or packed like the 102s. Code is [BNSIS](#) and they are sold per 100 at \$66 which is 25% less than the 102s.

### Small amplifier news

Last issue I announced the 50W version of a T-Amp from Dayton Audio. The DTA-100 was in very limited supply. We sold out of our initial shipment within a few days and when we tried to get more our supplier had also run out. It's taken more than 6 months for a new shipment to be available. But they are available now, and we have plenty in stock. The good news is that the stronger A\$ means the price has been lowered to \$187.

[http://www.decibelhifi.com.au/category45\\_1.htm](http://www.decibelhifi.com.au/category45_1.htm)

We have also had problems getting continuous supply of the Amphony transmitter/receiver/amplifier products. But we now have stock of new models which are all more powerful at the same prices. The L1520 system has been replaced by the L1540, now with 40W RMS per channel instead of 15W. This system enables you to send a signal from your source to a stereo receiver/amplifier which drives a pair of speakers as shown in the diagram here>. This is ideal for setting up wireless rear speakers in a home theatre system or beaming sound out to your patio.



The L1600 system now has 80W RMS mono amplifiers (the L1550 was 30W).

And the miniscule A200 amplifier provides up to 40W RMS per channel or 80W when used in bridged mode.

All these Amphony amps are suitable to be used with 8 or 4 ohm speakers.

[http://www.decibelhifi.com.au/category69\\_1.htm](http://www.decibelhifi.com.au/category69_1.htm)

Finally, on the small amplifier front we can now supply the Sure range of class D amplifier boards. These are intended for enthusiasts who want to build their own amplifiers. The boards are pre-assembled and tested and there are several power supplies available as well.

[http://www.decibelhifi.com.au/category15\\_1.htm](http://www.decibelhifi.com.au/category15_1.htm)



Amphony L1540 application

### Origin Live news

Origin Live has introduced two new tonearm designs.

The Onyx is a high performance arm built to a budget. The expertise gained from years at the forefront of high performance tonearms has been utilised to bring the best possible performance available from any arm at \$770.

The Zephyr tonearm is a new design that has been introduced between the Silver Mk4 and Encounter models at \$1540, while the Encounter is now \$2090.



The popular Silver tonearm is now up to version 4. The latest model now features the same underlying design as the popular Mk3C but has a new yoke and threaded base with VTA adjustment. Price has risen slightly to \$1100.

12" versions of all the arms are now available at \$605 more than the standard version.

Also available for enthusiasts are two armboard versions of each turntable, at about \$330 more than the standard version.

Finally, Origin Live have announced a new cartridge. The Aladdin is a moving iron design which works with normal moving magnet phono preamps. It is made for them by SoundSmith, a USA cartridge specialist. It is claimed to have lower moving mass than most moving coil cartridges and to outperform many cartridges costing much more. Price is \$880; we will be evaluating this cartridge over the next few weeks and will write a review in the next newsletter. More information is on our website [http://www.decibelhifi.com.au/category58\\_1.htm](http://www.decibelhifi.com.au/category58_1.htm)



Another minor but very useful item from Origin Live is a cable for burning in tonearm wiring. It works by plugging into the cartridge clips and injecting a signal from a CD player or radio tuner through the internal and external wires over 24 hours. This signal is at a much higher level than would normally be generated by a cartridge so the burning in process takes hours rather than weeks. Price is \$38.50.

### Thoroughbred power products

The performance of sensitive electronic equipment can be affected by the quality of the power supply it is connected to. Unfortunately our public power network was never designed with this in mind and power fluctuations and interference is commonplace. It is well known that businesses and hospitals spent huge amounts of money to stabilise their power supplies so that expensive and sensitive equipment is not damaged by voltage fluctuations, outages or transients. In a home audio system these power problems can cause audible artifacts and a level of background noise that masks fine details of the music. Most high quality equipment has power supplies which filter out a lot of this pollution. Even so when I visited the hi end audio show in Munich last year the exhibitors had massive power conditioners and special cables feeding their equipment with pure power to eliminate any such distortion.



But there is also a problem at the local level. Many if not most electronic audio devices use switch mode power supplies. They are noisy and inject noise back into the power cables so that if a number of units are plugged into a power board the adjacent units receive polluted power. An Australian manufacturer has come up with a solution. The Thoroughbred Power Interface has two filters on the incoming power lead plus one for each of the six power outlets. The latest version has sequenced power-on and power-off. This means that if the sources are plugged into the initial sockets and the power amps into the last ones, there will not be any turn-on thump through the speakers. It also makes it easy to power down the system (reverse order) so that there can be power savings due to the equipment not being left in standby mode all the time.

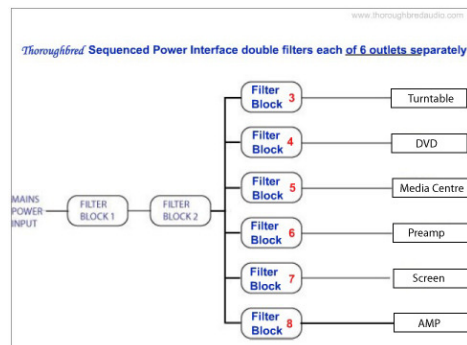

Thoroughbred also make high quality shielded power cables to any length required. These help prevent radiated interference getting into the power lines as well as providing a high current connection which is particularly important for power amps.

These products are now in the [Power Products category](#) on the website. There is also some good information on the [Thoroughbred Audio website](#) including a video and you can download the operating manual for the Power Interface.

### Versatile DAC

We have been selling the Trends Audio UD10 and UD10Lite audio converters for several years, and they are very good for taking the output from a computer's USB port and converting it to analog at higher quality than the sound card built into the computer. If you have your music stored in a lossless format the sound quality you can achieve via this connection is impressive, and the prices are very reasonable at \$242 and \$154.

Now there's a new competing unit from Musical Fidelity, part of their V-Series range. The V-DAC has USB, optical and coaxial inputs and analog RCA output



sockets. The digital inputs means that it can also be used with a CD/SACD as an external DAC. Price is \$352. I use one of these with my laptop to playback high resolution FLAC files with excellent results. [http://www.decibelhifi.com.au/category72\\_1.htm](http://www.decibelhifi.com.au/category72_1.htm)

## New Pro-Ject turntables

Most manufacturers are looking for ways to reduce their costs and improve the performance of their products. Recently, Pro-Ject introduced a new entry level turntable called the Essential which sells for \$396 compared to the Debut 3 at \$495. There is a second model which includes a phono pre-amp and USB output for \$550.

My initial reaction when hearing about these Essential models was scepticism, but when I looked at the specifications and design I could appreciate that the designers had made some intelligent choices in order to save manufacturing costs. For example, the tonearm is a uni-pivot, a well known design that is less expensive to make than one with precision bearings. The motor drives a belt which goes around the outside of the platter leading to better wow and flutter figures and the motor can have less torque (although the belt is more expensive). The platter is a one piece MDF which has good acoustic properties (Rega use it on their P2) and is cheaper than a sub-platter/outer-platter arrangement. Even a simple thing like the power switch at the back on the left near the motor saves money compared to having it at the front.



So all things considered I thought it was a very reasonable attempt to build a turntable that would sound good but sell for a A\$100 less than the Debut 3 which has been the entry level for several years. The Essential includes the Ortofon OM3E cartridge which is virtually the same as the OM5E on the Debut.

So how does it sound? A bit dull actually! If you are in the market or recommending an entry level turntable to a friend, spend the extra \$100, the Debut 3 sounds much better.

## Other Products

The newest member of the L'Art du Son family is a spray-on treatment for optical discs that both cleans and conditions the surface of CDs, DVDs, or SACDs. Priced at \$77.00 it is highly recommended by Harry Parson in *The Absolute Sound*. It's in the [CD/DVD Products](#).



The [Red Rose Music Vol.1 SACD](#) has proven to be very popular and we have secured another batch. Price has risen slightly to \$29.70 but it is well worth it.

Mobile Fidelity Sound Lab has introduced a new line of audiophile quality LPs. Each record is re-mastered and priced at \$45.00 for single and \$70.00 for double LPs. Initial artists include Inxs - Kick, The B52's, Bobby Darin - Love Swings, Echo and the Bunnymen - Heaven up Here, Dead can Dance - Into the Labyrinth & Spiritchaser. Also coming soon will be Sisters of Mercy - First and Last and Always, English Beat - Special Beat Service, Stevie Wonder - Talking Book, Rod Stewart - Every Picture Tells a Story, Bette Midler - The Divine Miss M, and KC and the Sunshine Band. Please email if you would like to order any of these.

## [Forward email](#)



This email was sent to [bmaddern@bigpond.net.au](mailto:bmaddern@bigpond.net.au) by [enquiry@decibelhifi.com.au](mailto:enquiry@decibelhifi.com.au) | Instant removal with [SafeUnsubscribe™](#) | [Privacy Policy](#).

Decibel Hi Fi | PO Box 536 | Sunnybank | Queensland | 4109 | Australia